

# Wealden Advertiser Property *South East*

COWDEN CLOSE, HORNS ROAD, HAWKHURST, KENT TN18 4QT

Telephone: (01580) 753322 Fax: (01580) 755104 Email: [property@wealdenad.co.uk](mailto:property@wealdenad.co.uk) Website: [www.wealdenproperty.co.uk](http://www.wealdenproperty.co.uk)

## *Media Pack*

- ABOUT US
- WHO'S WHO ...
- AREA MAP
- DISTRIBUTION AND CIRCULATION
- ADVERTISING RATES
- SUPPLIED ARTWORK GUIDE
- RESUMÉ

# About Us

Wealden Advertiser Property South East is a high quality magazine dedicated to the property market covering a large proportion of the affluent south-east of England.

Established within the Wealden Advertiser over 30 years ago, it has developed into a stand- alone magazine promoting property for sale and to rent within the Kent and East Sussex Weald and abroad. Interesting and informative editorial written by property professionals or those with a wealth of experience in the property world is included weekly, along with a comprehensive design and trade section, antiques and auction details plus related local businesses.

With an increasing circulation of over 40,000 copies weekly the magazine is free at over 400 carefully chosen pick up points or delivered, free of charge, to the door with local newspapers.

Our website [www.wealdenproperty.co.uk](http://www.wealdenproperty.co.uk) allows interested parties to view the magazine page by page, or download it, to browse at their leisure.

Advertised new builds within the region are identified on a map, both in the magazine and on the web-site, where we provide contact details and direct links to the builders' sites for further information. There are also direct links to local estate agents and a variety of sites, of interest to those in the process of moving, such as schooling, transport and price comparison sites etc.

Printed on-site to the highest quality Property South East provides an essential guide to those relocating and a vital tool to agents, developers and those seeking to promote their businesses in hard copy and via the World Wide Web.



# Who's Who ...

GENERAL MANAGER, Wealden Advertiser Ltd.

**GRAHAM THORN**

Telephone 01580 753322

graham.thorn@wealdenad.co.uk

EDITOR, Wealden Advertiser Property South East

**MELANIE PAYNE**

Telephone 01580 755115

melanie.payne@wealdenad.co.uk

PROPERTY SALES & MARKETING

**DEE FLOWER**

Telephone 01580 753322

dee.flower@wealdenad.co.uk

DESIGN & TRADE PROFESSIONALS, SALES & MARKETING

**FRANÇOISE FLETCHER and REBECCA HUNT**

Telephone 01580 753322

francoise.fletcher@wealdenad.co.uk  
rebecca.hunt@wealdenad.co.uk

GRAPHIC DESIGN

**STEVE PAYNE**

Telephone 01580 755116

property@wealdenad.co.uk

ACCOUNTS DEPARTMENT

**MARC O'HARE AAT**

Telephone 01580 755118

marc.ohare@wealdenad.co.uk

# Distribution and Circulation

Appledore	150	Grafty Green	50	Pembury	650
Ashford	550	Greatstone	100	Pett	75
Battle	605	Hastings	1,676	Petts Wood	250
Bearsted	175	Hawkhurst	1,597	Pluckley	375
Beckenham	150	Headcorn (1,225 copies door-to-door)	1,670	Robertsbridge	400
Beckley	75	Heathfield (900 copies door-to-door)	1,225	Rolvenden	250
Benenden	450	High Halden	160	Rye	870
Bethersden	125	Hildenborough	50	Sandhurst	350
Bexhill-on-Sea	720	Horam	100	Sedlescombe	225
Biddenden	356	Horsmonden	250	Sevenoaks	440
Bodiam	50	Hurst Green	350	Sissinghurst	300
Brenchley	110	Iden	75	Smarden	300
Broad Oak	150	Kingswood	100	Staplecross	150
Bromley	250	Lamberhurst	200	Staplehurst (1,600 copies door-to-door)	2,720
Burwash	380	Lenham	195	Stonegate	50
Borough Green	100	Little Chart	25	St. Michaels	975
Boughton Monchelsea	40	Longfield <i>railway station</i>	100	Sutton Valence	245
Catsfield	75	Loose	90	Ticehurst	355
Camber	150	Lydd	175	Tenterden (1,025 copies door-to-door)	2,463
Charing	125	Maidstone	475	Tonbridge	225
Chart Sutton	175	Marden (1,050 copies door-to-door)	1,331	Tunbridge Wells	1,005
Chelsfield <i>railway station</i>	100	Matfield	25	Wadhurst	670
Chislehurst	150	Mayfield	80	Westfield	250
Coxheath (600 copies door-to-door)	750	Meopham <i>railway station</i>	100	Winchelsea	90
Cranbrook (2,550 copies door-to-door)	3,351	New Romney	410	Wittersham	33
Cross In Hand	25	Netherfield	50	Woodchurch	180
East Peckham	200	Newenden	25	Wrotham	50
Egerton	75	North Down	75	Yalding	100
Etchingham	65	Northfleet	100		
Fairlight	100	Northiam	650		
Flimwell	125	Orpington <i>railway station</i>	100		
Frant	25	Otford	50		
Frittenden	75	Paddock Wood	575		
Goudhurst (650 copies door-to-door)	735	Peasmarsh	1,000		

plus posted or collected from our  
offices in Hawkhurst

Total distribution  
approximately **40,000**

# Advertising Rates

## ESTATE AGENT / GENERAL ADVERTISING

### COLOUR

Full page ..... £716 + VAT

Half page ..... £475 + VAT

Quarter page ..... £310 + VAT

### BLACK & WHITE

Full page ..... £440 + VAT

Half page ..... £320 + VAT

Quarter page ..... £175 + VAT

Front Page advert (colour only) 207mm x 65mm ..... £197 + VAT

Colour advertising per column cm ..... £13.<sup>90</sup> + VAT

Black & White advertising per column cm ..... £6.<sup>15</sup> + VAT

Lineage 40p per word (minimum advert £4.80) pre-pay only

## DESIGN & TRADE PROFESSIONALS

### COLOUR

Full page ..... £716.<sup>00</sup> + VAT

Half page ..... £357.<sup>00</sup> + VAT

Quarter page ..... £178.<sup>00</sup> + VAT

Eighth page ..... £ 89.<sup>00</sup> + VAT

Sixteenth page ..... £ 44.<sup>50</sup> + VAT

### BLACK & WHITE

Full page ..... £440.<sup>00</sup> + VAT

Half page ..... £220.<sup>50</sup> + VAT

Quarter page ..... £112.<sup>50</sup> + VAT

Eighth page ..... £54.<sup>50</sup> + VAT

Sixteenth page ..... £27.<sup>00</sup> + VAT

# *Important notice for advertisers supplying their own artwork*

**We prefer to receive high resolution  
print-ready PDF files**

(Please remember to check the 'embed all fonts' checkbox).

## **OTHER ACCEPTED FILE FORMATS:**

QuarkXPress, Adobe Photoshop, Illustrator, or InDesign files.

EPS, TIFF or JPEG images should have a minimum resolution of 250dpi.

All artwork is to be emailed to [property@wealdenad.co.uk](mailto:property@wealdenad.co.uk)

Alternatively, artwork can be can be supplied on CDs, DVDs or USB memory sticks.

All files should be CMYK conversion. We take no responsibility for errors arising from files being supplied in RGB or any other format, or for the incorrect reproduction of an advertisement if a colour proof is not supplied.

---

*Please note:* copy supplied in **Corel Draw, Microsoft Word, Publisher, Excel, Powerpoint** or **Microsoft Works** are **NOT** suitable.

***Any artwork that is supplied in these formats will often require resetting***

---

We cannot be held responsible for exact matching of logos, name styles and typefaces unless we are supplied with the item in digital form. It is not possible to ensure quality using letterheads or compliment slips

## Advertisement sizes - Estate Agent

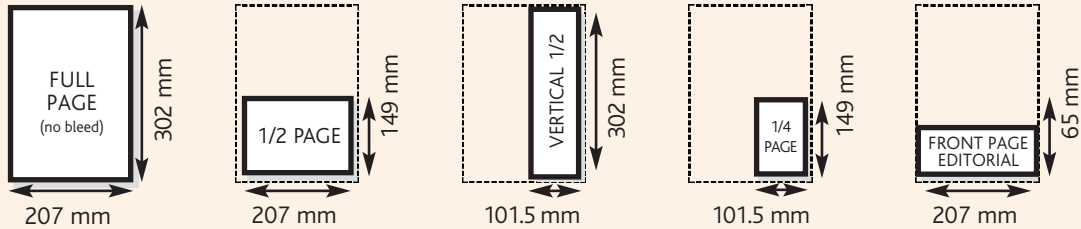

## Advertisement sizes - General Advertising

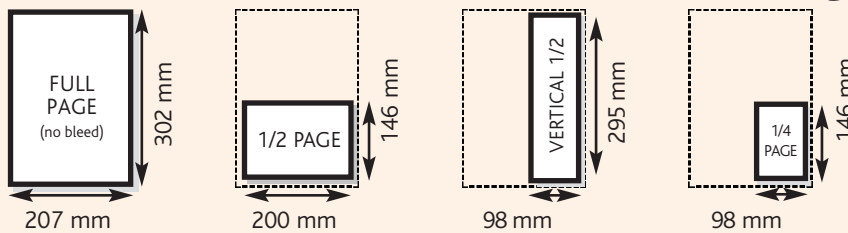

## Advertisement sizes - Design & Trade Professionals

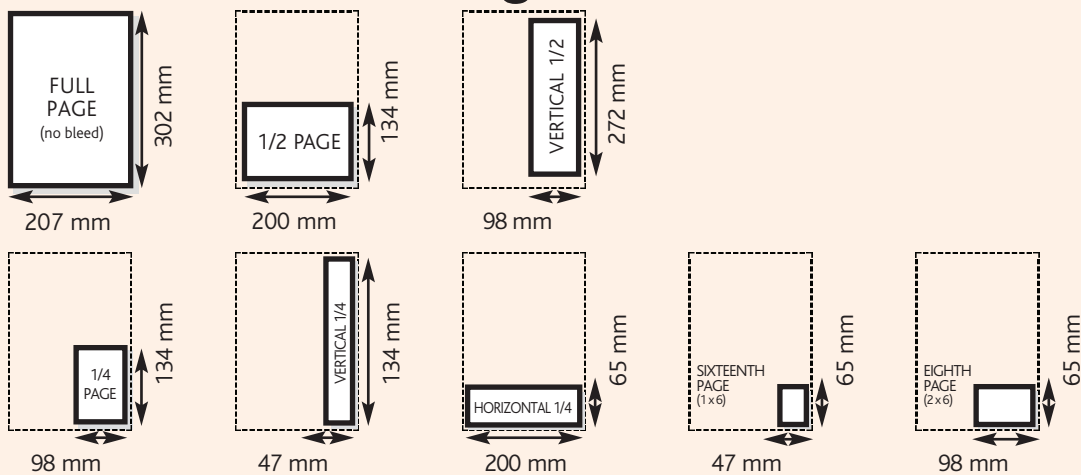

## Column Measurements

1 column .....	47 mm	2 columns .....	98 mm
3 columns .....	149 mm	4 columns .....	200 mm

**if you require any other sizes or details, please contact our Production Department on 01580 755116**

Our Graphic Designers are happy to advise or assist with the design of your artwork. This is a complimentary service, subject to Terms & Conditions.

# Resumé

- A comprehensive coverage of our area - approximately 40,000 copies distributed FREE
- Consistent superb reproduction and copy accuracy
- Constantly updated website [www.wealdenproperty.co.uk](http://www.wealdenproperty.co.uk) with page-to-view option and links to client's websites
- Early publication - distribution commencing every Wednesday
- FREE full page editorials, independently written to promote the more unique properties on the market
- Map identifying New Builds and Developments within our area can be seen both in our publication and on our website with links to developers for further information
- Editorial, design, production and distribution from one location
- Free graphic design service for our clients
- Interesting and informative editorial throughout
- Specialist Design & Trade classification promoting property-related businesses
- Experienced staff with a knowledge of estate agency
- Reliability. Over 20 years' experience of producing publications in the Kent & East Sussex Weald